

NEW PATENTS

This Section contains abstracts and, where appropriate, illustrations of recently issued United States patents and published patent applications filed from over 30 countries under the Patent Cooperation Treaty. This information was obtained from recent additions to the Pergamon PATSEARCH® on-line data base in accordance with interest profiles developed by the Editors.

Invitation to Readers

Readers' comments on the value of this section and suggestions for changes and improvements are invited and should be sent to the Patent Section Editor at either Pergamon Press, Inc. or Pergamon Press Ltd. at the address below.

PATSEARCH® and VIDEO PATSEARCH®

The Pergamon International PATSEARCH data base, covering U.S. patents published from 1971 to date and all PCT Applications, provides fast, low cost on-line searching. Subject matter searches of the data base can be made inexpensively from your own computer terminal. PATSEARCH is made available through the computer service of Pergamon InfoLine in London. On-line searching of this data base costs only \$80 (£40) per hour. A typical patent search can be made in less than ¼ hour. Search bureau service is also available at \$60 per search from Pergamon International Information Corporation.

VIDEO PATSEARCH is the revolutionary in-house patent search service that combines on-line searching with videodisc display of drawings and chemical structures. This unique new system permits the rapid scanning of drawings and chemical structures in conjunction with the on-line search of the patent text. Write for complete information.

Complete Patent Text Available

Copies of complete patents announced in this Section are available from Pergamon International Information Corporation for \$8 per copy. Payment with order is required. Orders outside North America add \$2 for air postage. Order by patent number from Pergamon International only.

4361009

MOVING BED HEAT STORAGE AND RECOVERY SYSTEM

Donald C Schluderberg assigned to The Babcock & Wilcox Company

An energy storage and recovery system designed for storing excess over demand energy generated by a steam cycle electrical generating plant during slack elec-

tricity demand periods and for recovering the stored energy to provide supplemental electricity during peak demand periods. The system utilizes one or more moving bed heat exchangers for transferring heat between the steam cycle of the power plant and a moving bed of refractory particles. Pipes and valves establish fluid communication between the heat exchangers and the steam cycle to supply fluid to selectively heat the moving bed of refractory particles or to cool them as the case may be. One or more insulated silos are provided for storing the refractory particles and means are provided for transporting the particles between the silos and the heat exchangers.

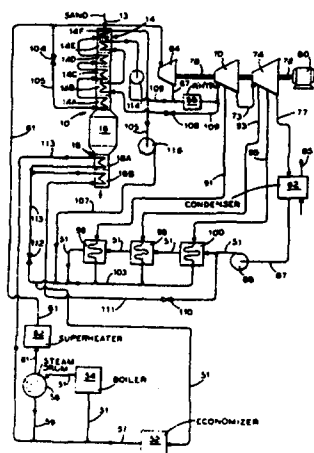

4360378

DIRECT REDUCTION OF IRON OXIDE CONTAINING MATERIAL WITH BIOFUEL

Olle Lindstrom

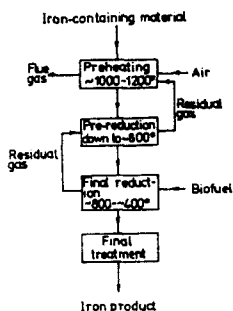

A new method is devised for the production of raw iron or so-called metallized iron ore. Biofuels i.e. preferably fuel wood and/or peat is in the final reduction brought into direct contact with the iron containing material in its solid state. Biofuels have very different properties compared to reduction agents on the basis of fossil fuels primarily coal and develop rapidly a reactive reduction gas at a comparatively low temperature. The new raw iron process is carried out with the iron containing material in its solid state of aggregation in different kinds of fluidized bed reactors in different system configurations.

4360339

FLUIDIZED BOILER

Henry J Blaskowski assigned to Combustion Engineering Inc

A fluidized bed call having a static ignition bed (18) of inert heat storage particles

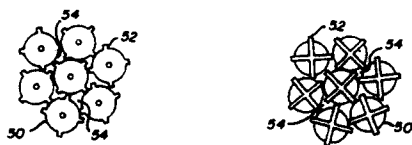

disposed immediately beneath and adjacent to a fluidizing region wherein fuel particles are combusted, characterized in that the heat storage particles are generally spherical in shape, each particle having a plurality of protuberances extending outwardly from the surface of the particle a preselected length thereby maintaining a minimum spacing, equal to the preselected length of the protuberances, between neighboring spherical particles

within the static ignition bed thereby ensuring that sufficient void space exists within the static ignition bed for the fluidizing air to flow upward through the static ignition bed into the fluidizing region without an excessive pressure drop and for the fuel particles to laterally penetrate the static ignition bed.

4359968

FLUIDIZED BED HEAT EXCHANGER UTILIZING A BAFFLE SYSTEM

Robert D Stewart assigned to Foster Wheeler Energy Corporation

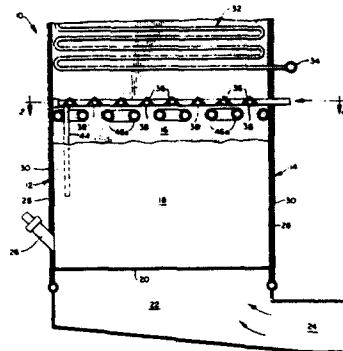

A fluidized bed heat exchanger in which a bed of particulate material is supported on a grate in a housing and air is passed through the grate and the particulate material to fluidize the bed and promote the combustion of combustible material contained therein. A baffle system is disposed in the housing for impacting with the entrained particulate material in the air and gaseous products of combustion to remove the latter material and permit it to fall by gravity back to the bed. A series of tube sections are provided in the housing for directing the air and gaseous products to the baffle means and gases are injected from the proximity of the baffle means downwardly toward the bed.

4359493

METHOD OF VAPOR DEPOSITION

Vern A Henery assigned to PPG Industries Inc